

traxon

Mounting Guide

BEFORE MOUNTING, PLEASE READ THE USER MANUAL FOR CABLING AND CONNECTION DETAILS.

DOT XL-6
DOT XL-9

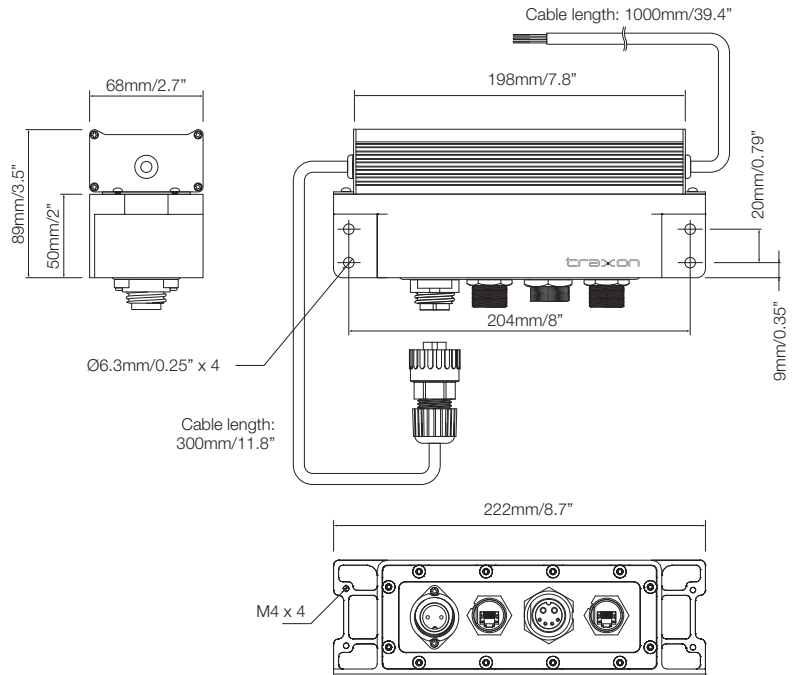
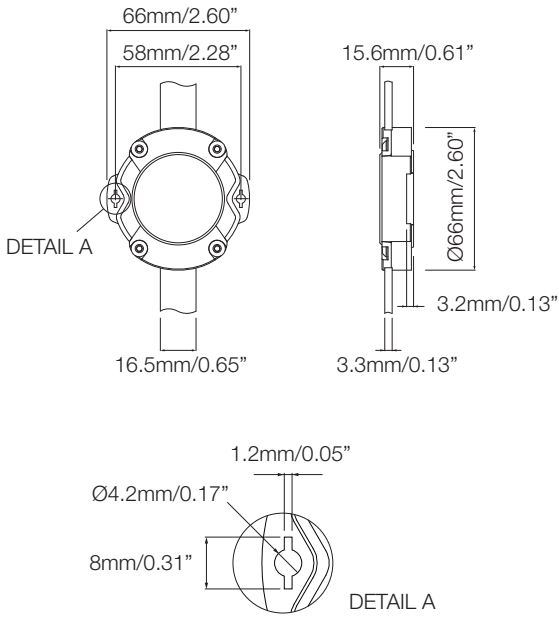

The normal function of the product may be disturbed by strong Electro-Magnetic Interference. If so, please reset the product according to the instruction manual to resume normal operation. In case the function does not resume please relocate the product positions.

Mounting the Dot XL

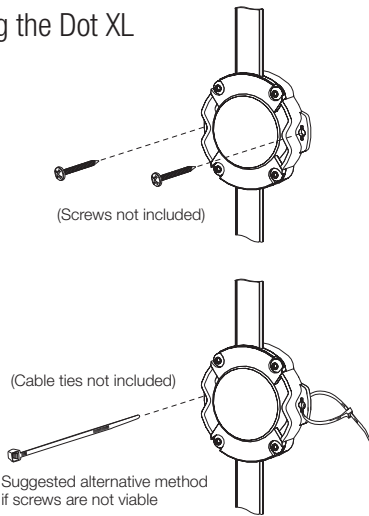

CAUTION: Always use the housing unit for mounting. Handle string with care. Improper handling of lead cable and string will cause damage.

Mounting the LED Engine and Pixel Distributor

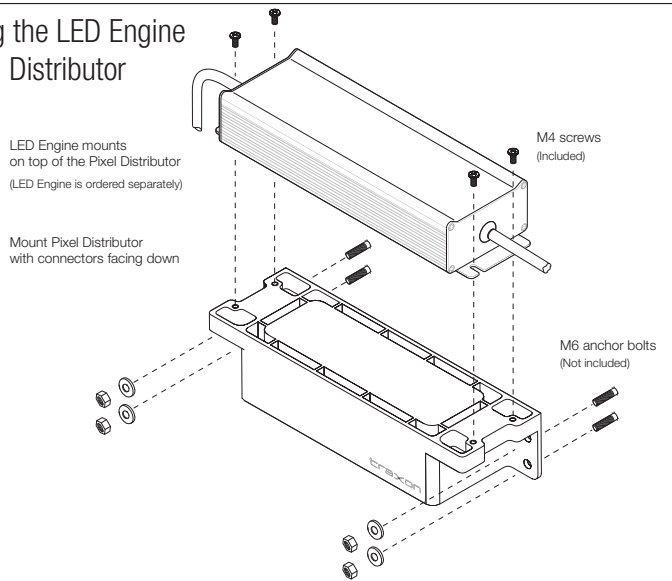

Terminating the Dot XL cable and Sealing with End Cap (End cap not included)

